

Goliath™ G300C

HIGH COMPACTION REAR LOADER



*Simple Lightweight Design
for High Compaction Reliability*



So Advanced, It's Simple



Refuse Hauling Solutions, LLC

E-Z Pack

GOLIATH G300C

High-Compaction Rear Loader

SPECIFICATIONS

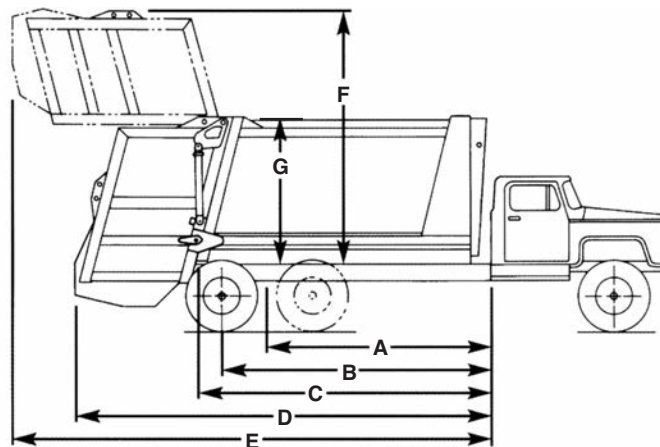
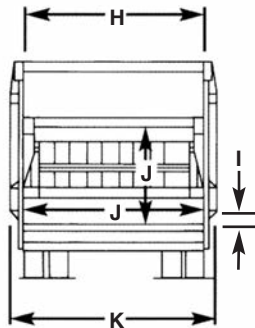

MODEL	G300C-18	G300C-20	G300C-25	G300C-31
CAPACITY	18 Cu. Yd. (13.8 m ³)	20 Cu. Yd. (15.3 m ³)	25 Cu. Yd. (19.1 m ³)	31 Cu. Yd. (23.7 m ³)
A CAB TO TRUNNION (CT)	N/A	126" - 132" (3200 - 3353 mm)	156" - 162" (3962 - 4115 mm)	190" - 196" (4826 - 4978 mm)
B CAB TO AXLE	120" - 126" (3048 - 3200 mm)	138" - 144" (3505 - 3658 mm)	N/A	N/A
C DECK LENGTH CLEAR PLATFORM	155" (3937 mm)	170" (4318 mm)	204" (5182 mm)	244" (6198 mm)
D LENGTH (Including Tailgate)	223" (5664 mm)	238" (6045 mm)	272" (6909 mm)	312" (7925 mm)
E LENGTH (Tailgate Raised)	262" (6655 mm)	277" (7036 mm)	311" (7899 mm)	351" (8915 mm)
F HEIGHT (Tailgate Raised)	155.5" (3950 mm)			
G HEIGHT (Above Chassis Frame)	90.25" (2292 mm)			
H INSIDE WIDTH (Body)	91" (2311 mm)			
I LOADING HEIGHT (Below Frame)	Up to 5.5" (140 mm) below chassis frame, depending on options selected			
J LOADING OPENING	80" wide (2032 mm) x 58" (1473 mm) high			
K OUTSIDE WIDTH	96" (2438 mm)			
HOPPER CAPACITY	3 Cu. Yd. (2.3 m ³)			
WEIGHT	12,140 lbs. (5507 kg)	12,410 lbs. (5629 kg)	13,025 lbs. (5908 kg)	13,825 lbs. (6271 kg)

Chassis specifications listed are intended as general guidelines only. Each chassis selection should be made on an analysis of the weight distribution for the particular chassis/body combination including optional equipment and anticipated payloads

CONSTRUCTION AND OPERATIONAL DETAILS	
Body Floor	7 ga. (4.55 mm) 50,000 PSI
Body Sides	7 ga. (4.55 mm) 100,000 PSI
Body Roof	10 ga. (3.42 mm) 50,000 PSI
Ejector Panel	7 ga. (4.55 mm) 50,000 PSI
Hopper Floor	1/4" (6.35 mm) 155,000 PSI 400 BHN
Hopper Sides	Lower 1/4" (6.35 mm) 100,000 PSI Upper 7 ga. (4.55 mm) 50,000 PSI
Packing Panel	7 ga. (4.55 mm) 50,000 PSI
Packing Cylinders (2)	5-1/2" (140 mm) (D.A.)
Sweep Cylinders (2)	4" (102 mm) (D.A.)
Tailgate Cylinders (2)	3" (76 mm) (D.A.)
Ejector Cylinder (1)	18 Yd - 6-1/2" (165 mm) 2-Stage DA 20 Yd. - 6-1/2" (165 mm) 2-Stage DA 25 Yd. - 6-1/2" (165 mm) 3-Stage DA 31 Yd. - 7-1/2" (191 mm) 4-Stage DA
Hydraulic Oil Tank	37 Gallons (140 Liters)
Hydraulic Pump	27 G.P.M. @ 1200 RPM (102 Liter/Min.)
Hydraulic Filters	Suction - 100 Mesh Return - 10 Micron
System Operating Pressure	2,200 PSI

SPECIAL NOTES:

- 1) PTO Requirements are 44 HP @ 1200 RPM (Torque Rating 212 Ft. Lb.) Minimum
- 2) Chassis MUST be equipped with diesel engine and requires variable speed governor with body builders connection for engine remote throttle, programmed and preset to approximately 1400 RPM.
- 3) Chassis lighting must be set up and programmed for heavy duty package and duplicate independent stop and turn signals

Standard Equipment

- Manual Controls
- Tailgate Props
- Back Up Alarm
- Body Lifting Eyes
- High Mount Light Package
- ICC Lights and Reflectors Meet DOT Requirements
- Non-Skid Riding Steps at Rear Corners of Tailgate
- Streetside and Curbside Buzzers
- Automatic Latch-Unlatch Tailgate

Optional Equipment

- Air Shift or Hot Shift PTO's
- Street Side Access Door
- Front Mount Pump
- Dual Hopper Flood Lights
- Rear Body Side Liner
- 10,000 lb. (4536 kg) Overhead Winch*
- 14,000 lb. (6350 kg) Reaving Cylinder Winch*
- System Pressure Gauge
- 1-3 Yard (.76 - 2.3 m³) Hydraulic Container Attachment

* Optional Container Dumping Devices Handle Containers up to 10 Cubic Yards (7.6 m³)

Operational Features

- **COMPACTION CYCLE:**
Manual hydraulic, automatic split cycle, fully reversible
- **CYCLE TIME:**
28-30 seconds, reload @ 10-12 seconds
- **PACKER PANEL:**
Curved, one-piece construction
- **EJECTOR PANEL:**
Travels in steel guide shoes, floor level track
- **PACKING CYLINDERS:**
Positioned away from refuse for trouble-free operation
- **EJECTOR CYLINDER:**
Heavy Duty, double-acting, telescopic

E-Z Pack Refuse Hauling Solutions, LLC, reserves the right under its Product Improvement Program to modify construction and/or design and furnish equipment without reference to illustrations and specifications shown herein. All specifications are subject to change without notice.



E-Z Pack Refuse Hauling Solutions, LLC
200 Ladish Road • Cynthiana, KY 41031
Phone 859-234-1100 • Fax 859-234-0061
www.ezpacktrucks.com

Authorized Distributor: